

ITEM NO.	DRAWING NO.	DESCRIPTION	SIZE	FINISH	QTY.
1	13181	DOUBLE TRIANGULAR FRAME D400	420 x 420 x 100	AQUABOND PRIMER AC500 MATT BLACK 60 MICRONS	1
2	13180	GRATE DOUBLE TRIANGULAR D400	420 x 420 x 100	AQUABOND PRIMER AC500 MATT BLACK 60 MICRONS	2
3	N/A	TENSION PIN	Ø14 x 24MM	N/A	2
4	13333	THREADED ROD	M10 x 105mm	N/A	2
5	N/A	HEX NUT	M10	N/A	4

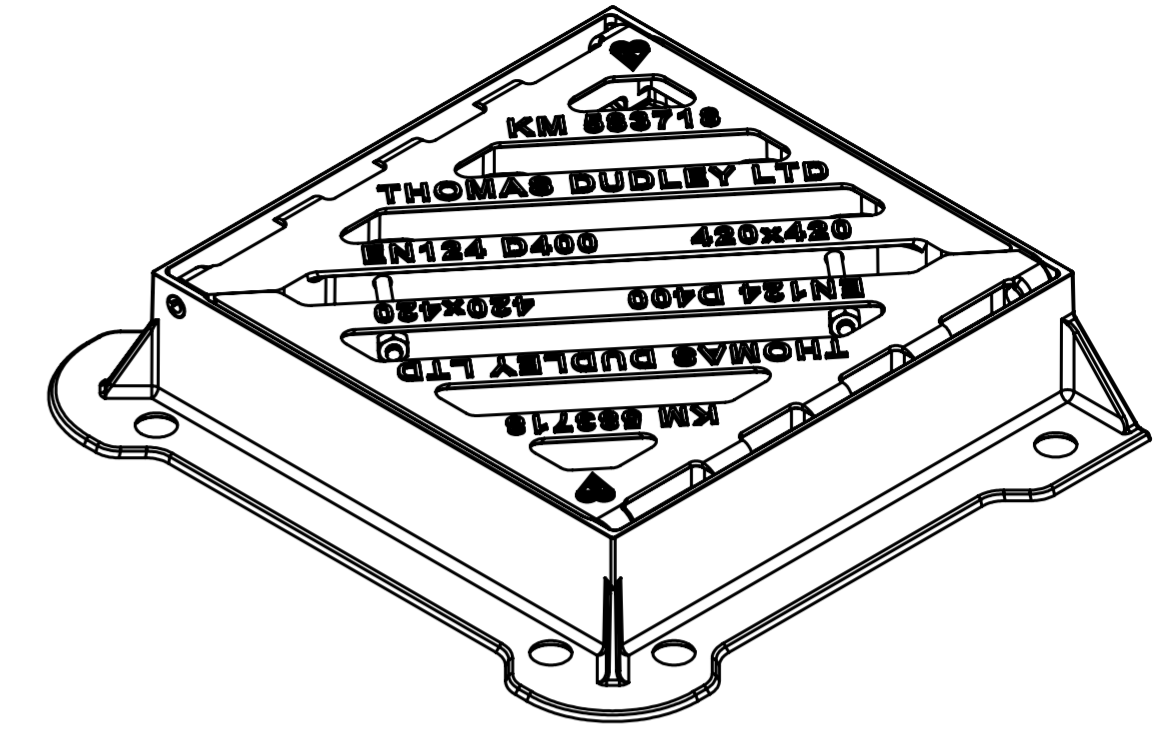

PICTORAL VIEW
FOR REFERENCE ONLY
SCALE 1:5

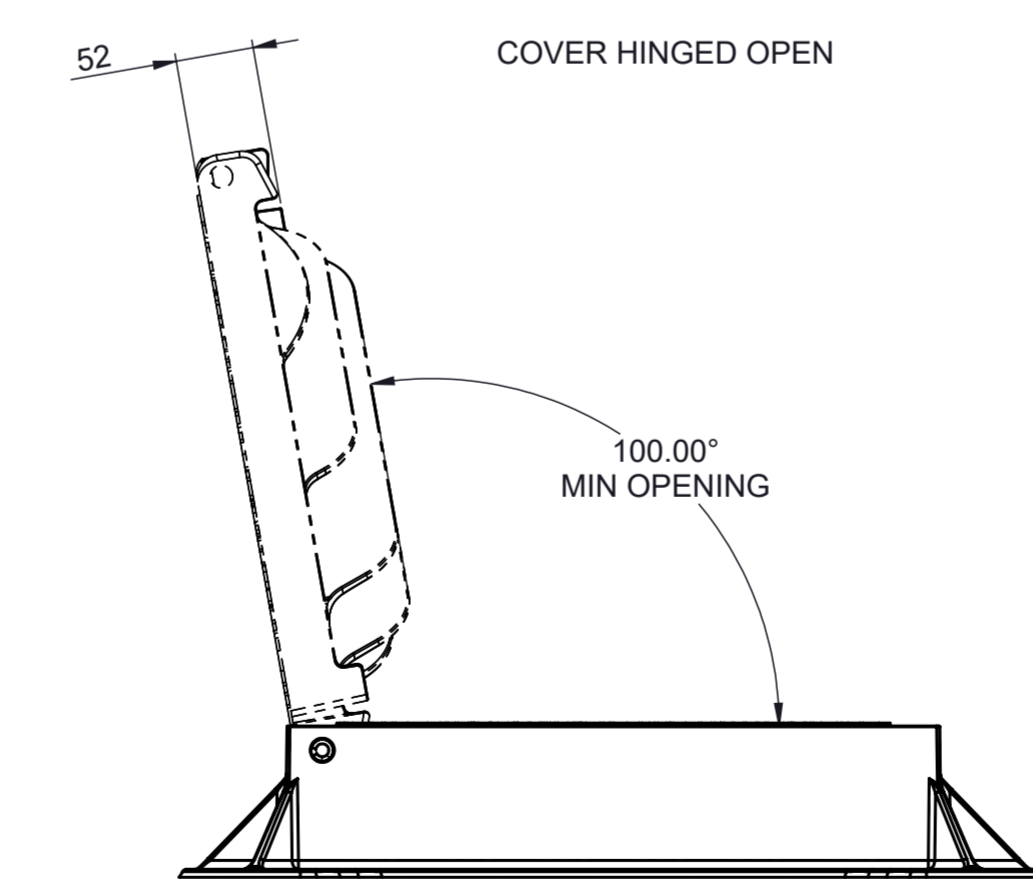
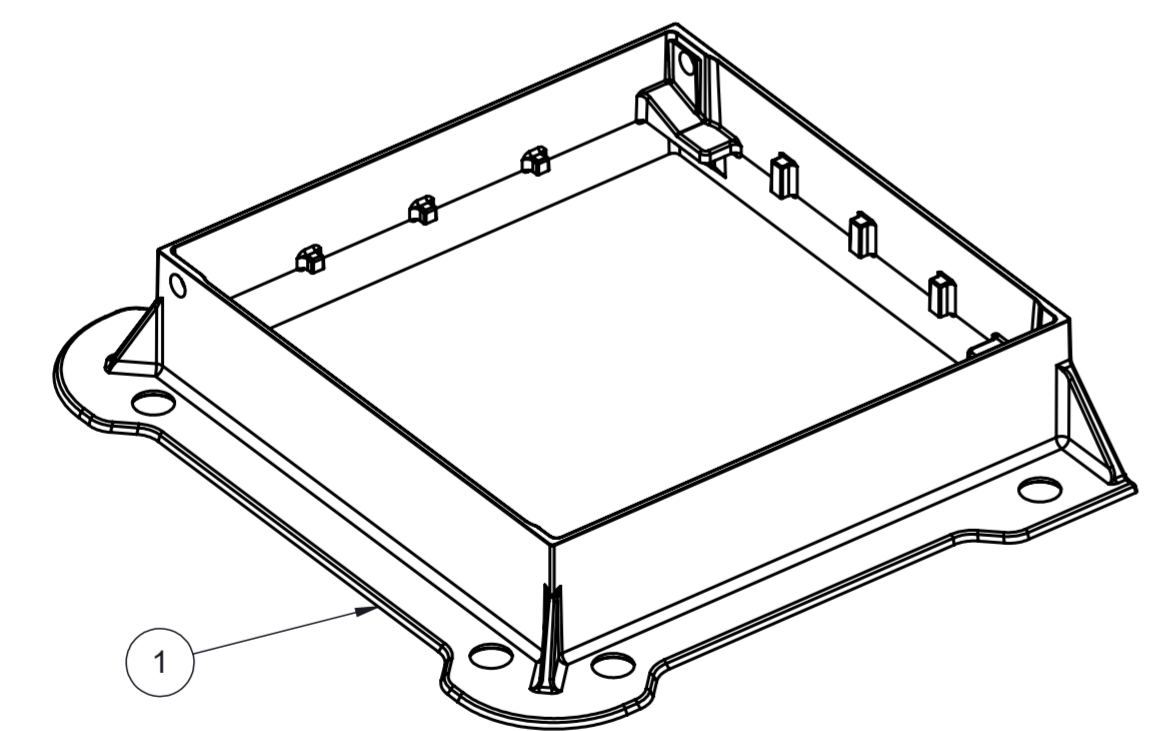
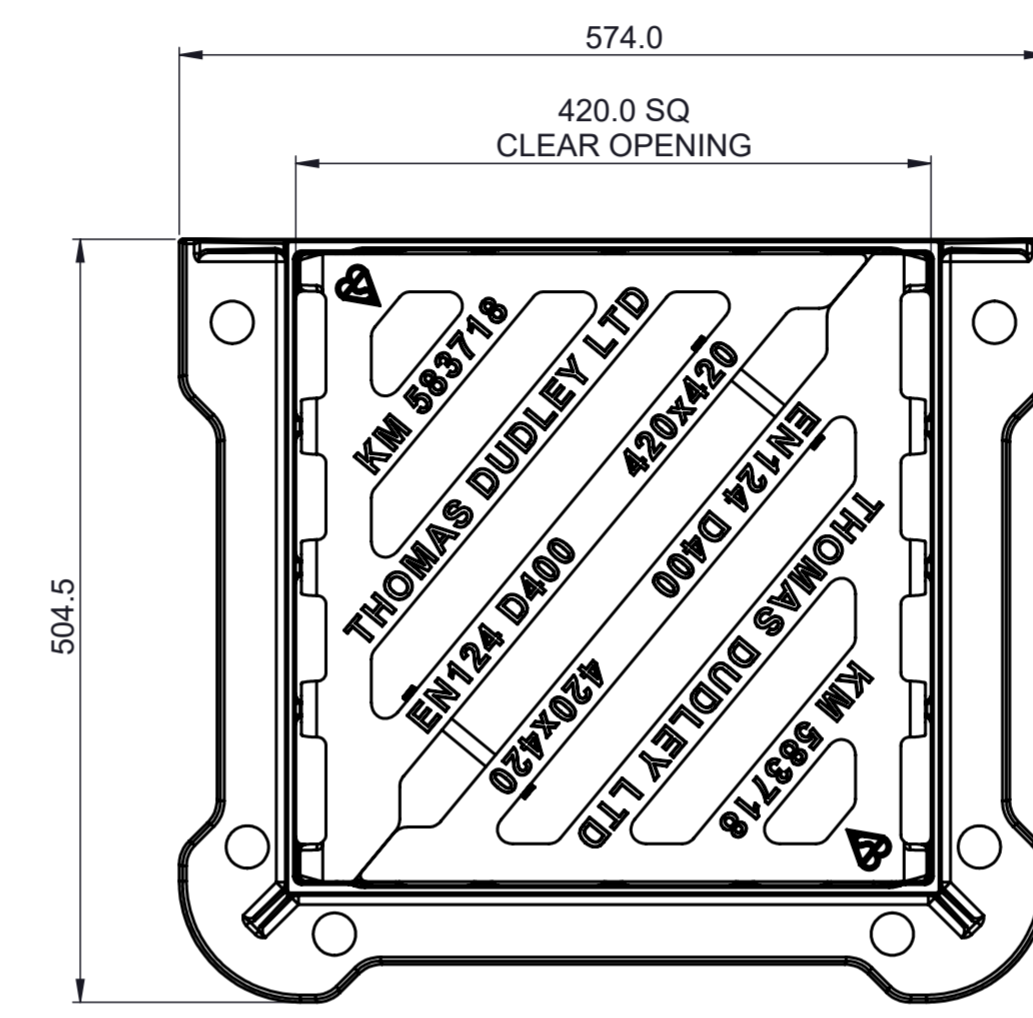
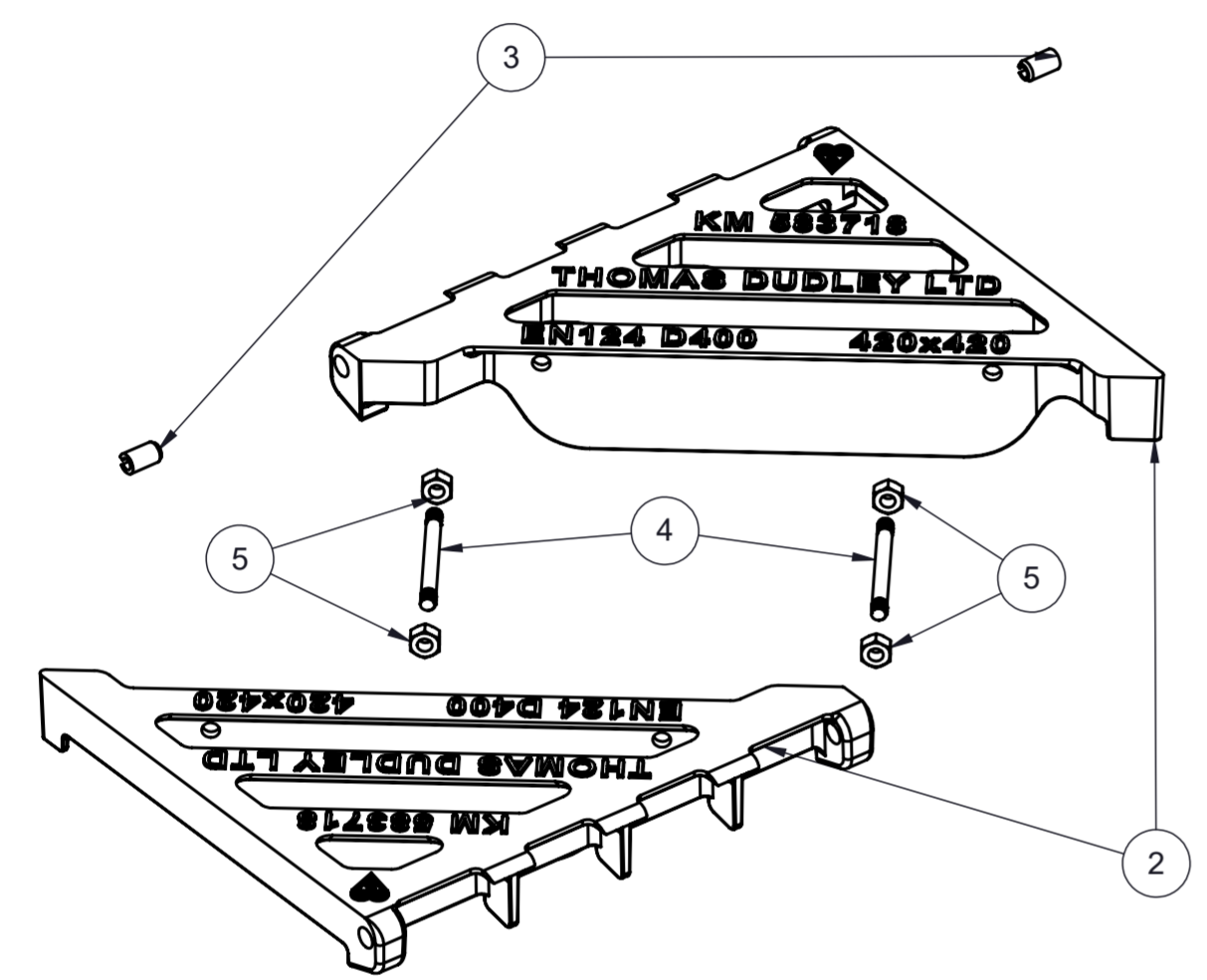

- NOTES:
- FULLY HA104/09 COMPLIANT SUITABLE FOR HIGH INTENSITY TRAFFIC
 - DEPTH OF INSERTION 52MM
 - SOLID FLANGES
 - HINGED AS STANDARD

CDC	HM	FIRST ISSUE	02/01/18	1
MOD	CHK	MODIFICATION	DATE	ISS

TD Thomas Dudley Ltd.
P.O.Box 28, Birmingham New Road
Dudley, West Midlands, DY1 4SN
Telephone: 0121 530 7000
www.thomasdudley.co.uk

This document and any design incorporated in it is the property of Thomas Dudley Ltd. It is strictly confidential and must be used only for the purpose for which it is supplied and expressly authorised. Reproduction, manufacture or communication to third parties, in whole or part without prior written authorisation is strictly prohibited and is an infringement of Thomas Dudley Ltd's copyright and/or design right. Other intellectual property rights may also subsist in any part of this document or design or invention incorporated within them. Please contact Thomas Dudley Ltd for further information.

A2 LINEAR TOLERANCE:
ISO8062-3:2007 TO CT-9
UNLESS SPECIFIED ON
DRAWING
DIMENSIONS IN mm
DO NOT SCALE

DRAWN	CHECKED	SHEET
C CORBETT	H MISTRY	1 of 1
DATE	DATE	SCALE
02/01/2018	02/01/2018	1:5

PROJECT
UTILITY CASTINGS
DESCRIPTION
**DOUBLE TRIANGULAR GRATE
AND FRAME
420x420x100**

DRG No.	ISSUE
13182	1

	REFER TO COMPONENT	REFER TO COMPONENT
PART No.	MATERIAL	APPLIED FINISH & COLOUR