

B-B

Technical Requirement

1. The castings will be well finished without any visible defects, such as shrinkage cavities, underfill, cracks, cold shuts and etc;
2. Without the marking of the curving of castings R3 and pattern draft (draft angle) 1.5°;
3. The casting inspection will be complied with the EN124 standard;
4. Tolerance: ISO8062:1994CT-12;
5. The discharge area after assembled is 936.01cm²

DWG NO.:	ASC-RS60304G-1	
LOADING:	D400	
DESCRIPTION:	600X300X100	LOAD TEST EN124
MATERIAL:	Ductile Iron Grade 500/7	
THIS DRAWING IS THE PROPERTY OF SHANXI ASCENT INDUSTRIAL CO.,LTD, AND CAN NOT BE COPIED OR DUPLICATED WITHOUT PRIOR WRITTEN PERMISSION, ONCE THIS DRAWING BE USED OTHER PLACE, WILL HAVE LAW RESPONSIBILITY		
DATE:	01-11-2018	

Shanxi Ascent Industrial Co.,Ltd

ADDRESS: 7-3408, PingYangJingYuan, TaiYuan, ShanXi

Tel: 0086 351 7922077 Fax: 0086 351 7921035

Mobile: 0086 13834557191 E-mail: info@ascentcn.com

www.ascentcn.com



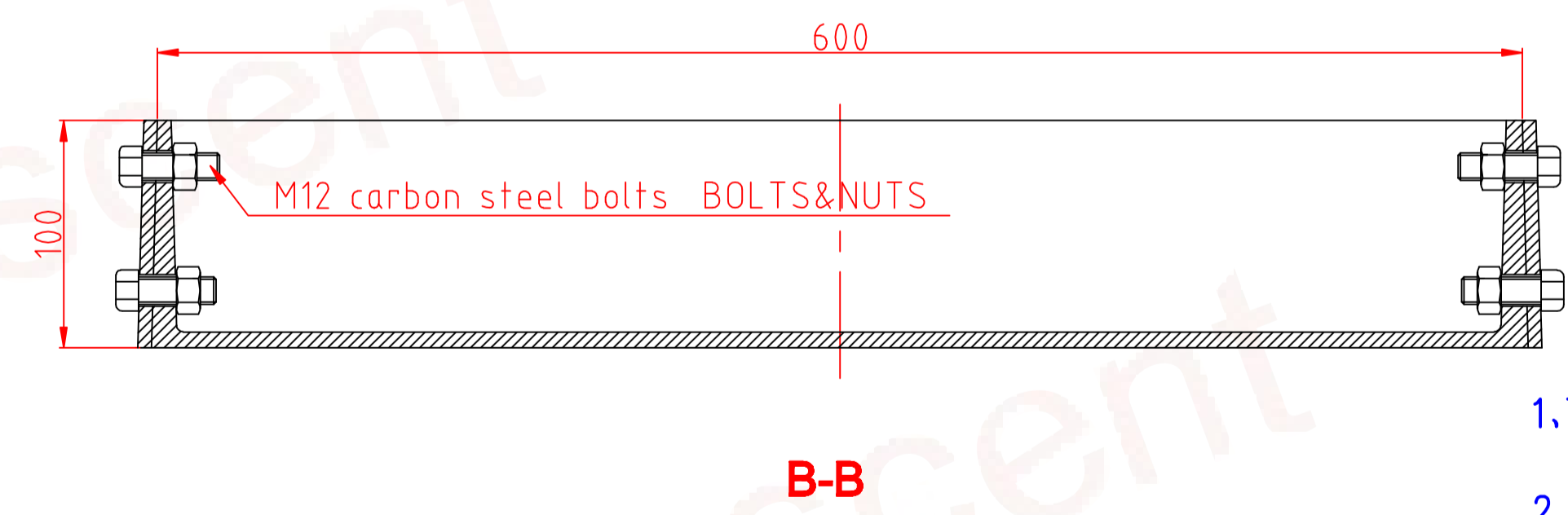
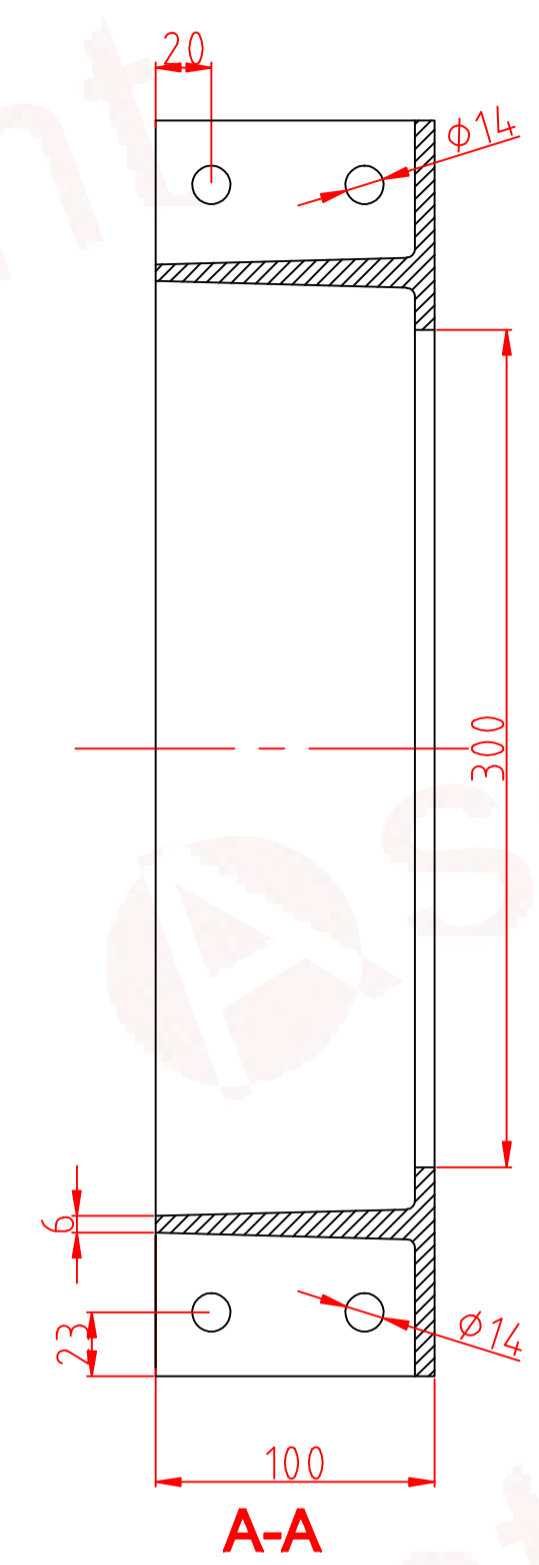
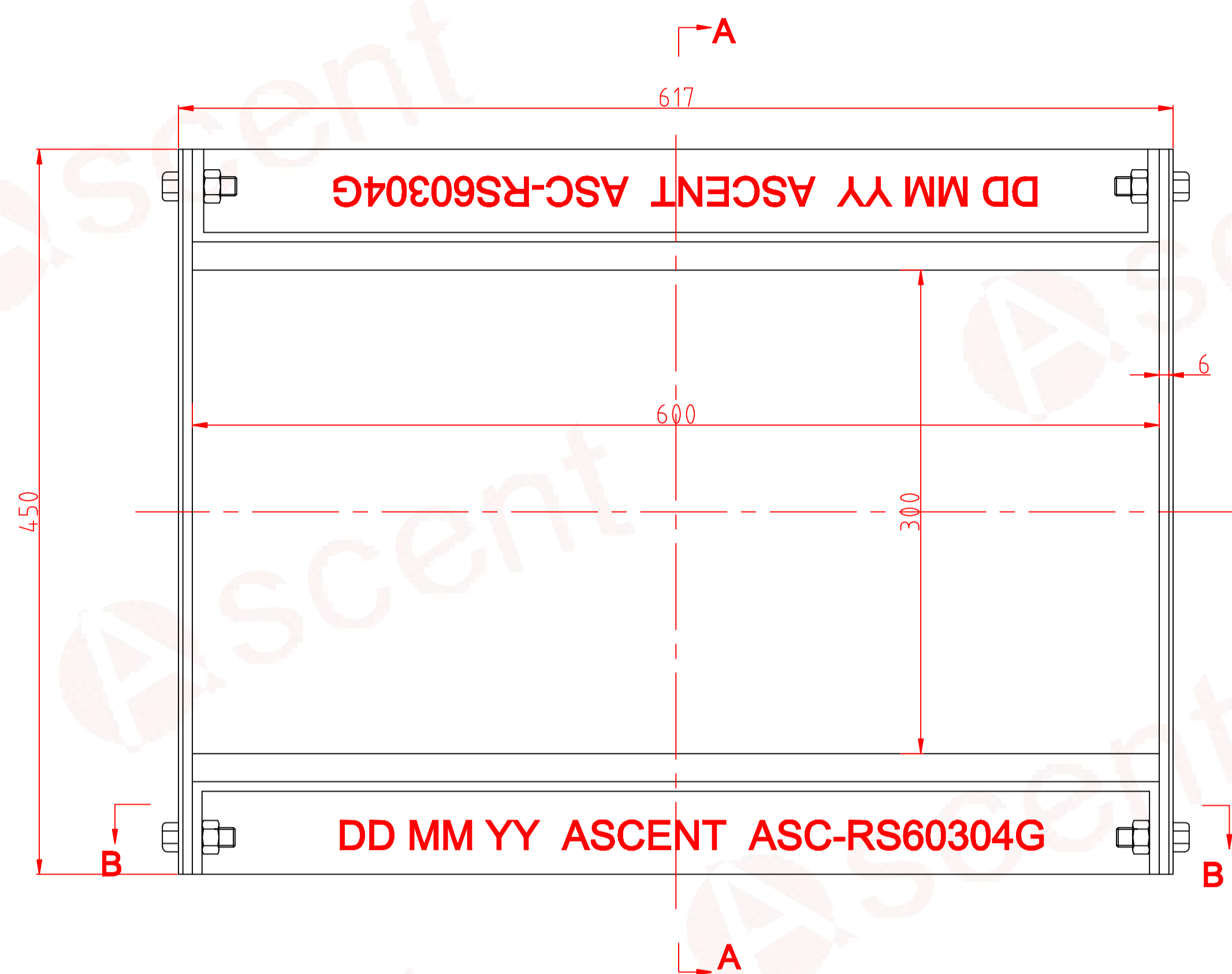

Technical Requirement

1. The castings will be well finished without any visible defects, such as shrinkage cavities, underfill, cracks, cold shuts and etc;
2. Without the marking of the curving of castings R3 and pattern draft (draft angle) 1.5°;
3. The casting inspection will be complied with the EN124 standard;
4. Tolerance: ISO8062:1994CT-12;

DWG NO.:	ASC-RS60304G-2	
LOADING:	D400	
DESCRIPTION:	600X300X100	LOAD TEST EN124
MATERIAL:	Ductile Iron Grade 500/7	
THIS DRAWING IS THE PROPERTY OF SHANXI ASCENT INDUSTRIAL CO.,LTD, AND CAN NOT BE COPIED OR DUPLICATED WITHOUT PRIOR WRITTEN PERMISSION, ONCE THIS DRAWING BE USED OTHER PLACE, WILL HAVE LAW RESPONSIBILITY		
DATE:	01-11-2018	

Shanxi Ascent Industrial Co.,Ltd

ADDRESS: 7-3408, PingYangJingYuan, TaiYuan, ShanXi

Tel: 0086 351 7922077 Fax: 0086 351 7921035

Mobile: 0086 13834557191 E-mail: info@ascentcn.com

www.ascentcn.com