



GULLY GRATING AND FRAME

**Class D400
EN124 : 1994**

**CA1040DVL GRIL CAN VER
NF
CHANNEL GRATING**

**EN GJS 500-7 Iron
ISO 1083 / EN1563**

DESIGN FEATURES :

- **Material(s) :**
 - ☞ SG Iron to ISO 1083 / EN1563, Grade 500-7.
- **Design load :**
 - ☞ 400 kN to EN 124 : 1994

Installation area :
designed for gully tops located in motorways and road, low carriage way as exchangers, crossroads, rest areas, car parking place...

- **Coating :**
 - Non toxic waterbased black paint.

- **Product Certification :**
 - NF Mark
 - This quality mark certifies conformity to the 'NF' regulation 110 and other additional features as highlighted (☞) by the authorising body AFNOR CERTIFICATION,
 - 11, rue Francis de Pressensé
 - F-93571 LA PLAINE SAINT DENIS CEDEX

SPECIAL FEATURES :

- **Remark(s) :**
 - Set of gratings bolted down to frame bars which can not be used separately
- **Frame bearing pressure :**
 - ☞ $p \leq 7.5 \text{ N/mm}^2$.
- **Mass :**
 - Grating : 42 kg.
 - Product total : 69 kg.
- **Surface finish :**
 - Raised anti-skid pattern improves drainage.
 - Bars special design provides maximum water drainage
 - ☞ Waterway $\geq 30\%$: 1563 cm².
- **Grating type :**
 - Rectangular : 400 x 1000 mm.
 - Selflocking anti-vandal grating : Spring front/rear bars allow to lock individual gratings into a continuous run.
 - ☞ Depth of insertion : $e = 36 \text{ mm}$.
- **Securing of cover/grating within frame :**
 - ☞ Grating bolted down to frame bars by means of 2 HM 12x45 screws + brake washer and M12 captive square nut
- **Frame type :**
 - Frame bars and gratings seatings incorporate a special feature designed to secure the grating within the frame bars lengthwise and sideways
 - ☞ Depth of frame bars : 100 mm

OPTION(S) :

Pair of iron end bars, to be ordered separately.

CIVIL ENGINEERING :

Frame bars incorporate 2 $\varnothing 14 \text{ mm}$ holes.
Frame bars incorporate 2 square holes for plug levelling(option)
Suitable for 1 m long prefabricated concrete ducts

HANDLING :

REMOVAL :
Unscrew bolts and prise against spring latch to unlock grating

RESETTING :
Return the grating, brackets being engaged under adjacent bar
Kick down to lock grating.
Screw bolts with 8 m.kg mini tightening torque
Screw bolts with 8 m.kg mini tightening torque

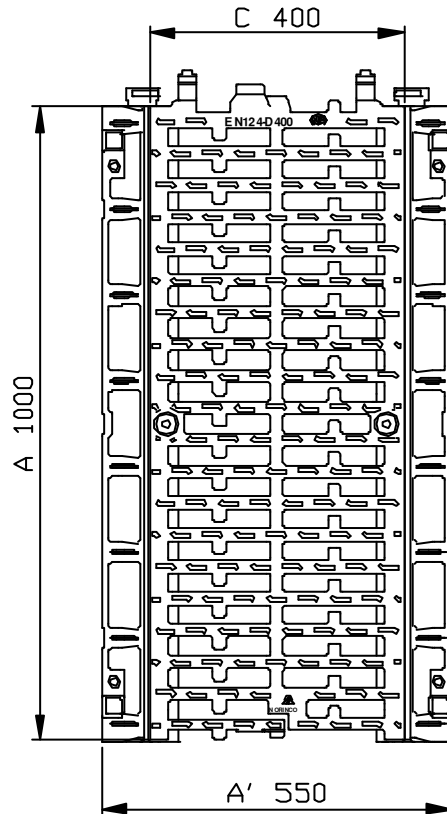
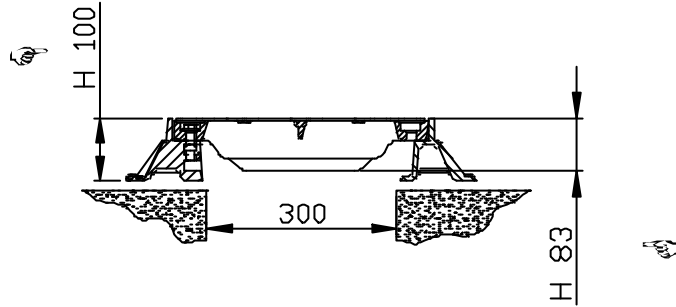

- (☞) Certified characteristics.
- Weights (kg), dimensions (mm) and drawings provided for your guidance.
- We reserve the right to modify specifications without prior notice.
- Uncontrolled distribution.

CONFIDENTIAL
Property of EJ EMEA
Not to be used without permission.

EJ
ZI De Marivaux | Saint-Crépin Ibouvillers |
BP50409 | 60544 Méru Cedex | France

Système Qualité ISO 9001 - ISO 14001 - OHSAS 18001

ejco.com

Data sheet : FT_522824
Date updated : 05.11.2012
Printed : 27.11.2012