



**ACCESS COVERS & FRAMES**

**Class D400  
EN124 : 1994**

**TI4S090060AV11 DECOR NF**

**EN GJS 500-7 Iron  
ISO 1083 / EN1563**

**CARRIAGEWAY COVER**

**DESIGN FEATURES :**

- **Material(s) :**  
☞ SG Iron to ISO 1083 / EN1563, Grade 500-7.
- **Design load :**  
☞ 400 kN to EN 124. Group 4 installation area - carriageway of roads (including pedestrian streets), hard shoulders and parking areas, for all types of roads vehicles (and lower groups).
- **Coating :**  
Non toxic waterbased black paint.
- **Product Certification :**  
NF Mark  
This quality mark certifies conformity to the 'NF' regulation 110 and other additional features as highlighted (☞) by the authorising body AFNOR CERTIFICATION, 11, rue Francis de Pressensé F-93571 LA PLAINE SAINT DENIS CEDEX

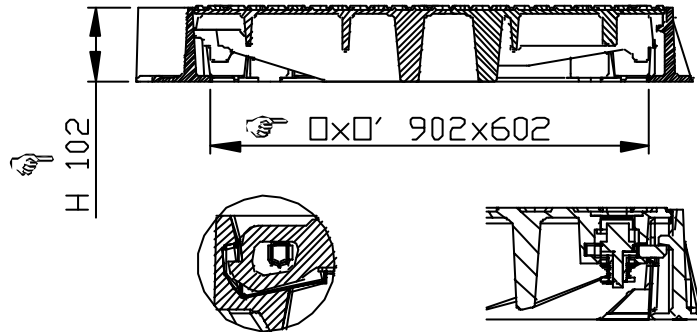

**SPECIAL FEATURES :**

- **Mass :**  
Each triangular cover : 23.3 kg  
Product total : 133.8 kg.
  - **Seatings ensure non-rock stability and silence :**  
☞ Non-rocking by means of three-point suspension.
  - **Frame bearing pressure :**  
☞  $p \leq 7.5 \text{ N/mm}^2$ .
  - **Surface finish :**  
Cover: Anti-slip surface with 4L patented design.
  - **Securing of cover/grating within frame :**  
☞ Secured by locking mechanism.
  - **Frame type :**  
Rectangular monoblock as cast.  
☞ Depth of insertion :  $e = 52 \text{ mm}$ .
  - **Cover type :**  
☞ Opening angle  $\approx 110^\circ$ .
- Locking system by successive overlap of covers sections and locking of the last section on the frame.  
Secured (Cover block at  $90^\circ$  preventing accidental closure).

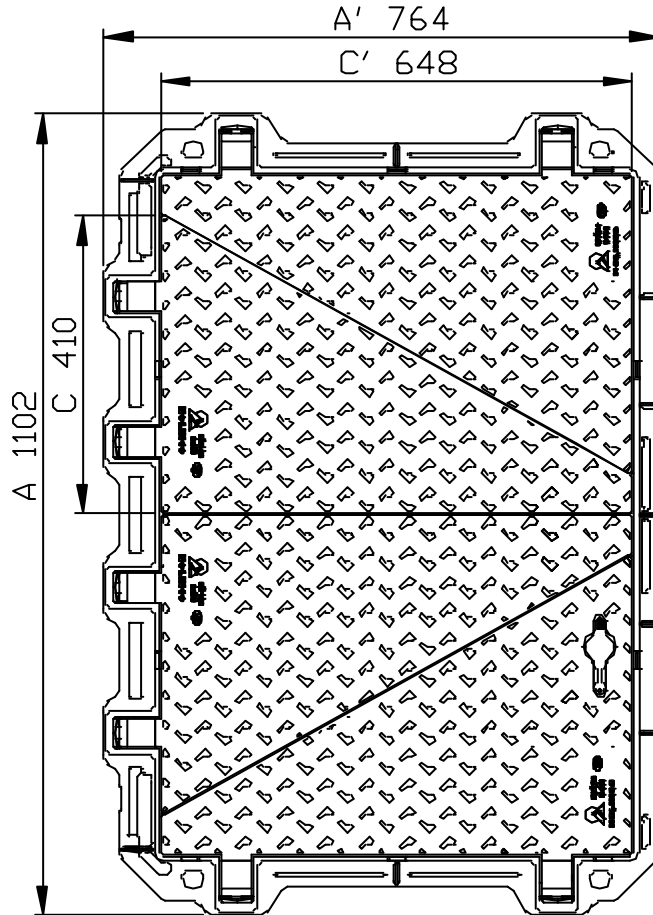

**HANDLING :**

Cover can be removed at  $90^\circ$  angle.

**OPTION(S) :**

- Badging : Please enquire.  
Badging space depending on size of cover.

- (☞) Certified characteristics.
- Weights (kg), dimensions (mm) and drawings provided for your guidance.
- We reserve the right to modify specifications without prior notice.
- Uncontrolled distribution.

**CONFIDENTIAL**  
Property of EJ EMEA  
Not to be used without permission.

**EJ**  
ZI De Marivaux | Saint-Crépin Ibouvillers |  
BP50409 | 60544 Méru Cedex | France  
  
Système Qualité ISO 9001 - ISO 14001 - OHSAS 18001  
  
ejco.com

**Data sheet :**  
FT\_532008  
**Date updated :**  
02.04.2012  
**Printed :** 26.04.2012