

ITEM NO.	DRAWING NO.	TITLE	DESCRIPTION	VERSION	QTY.
1	14636	750 x 450 x 100	D400 DOUBLE HINGE FRAME	-	1
2	14637	750 x 450	D400 2 PART DOUBLE HINGE COVER	MASTER	1
3	14637	750 x 450	2 part double hinge Cover	SLAVE	1
4			TURNBUCKLE LOCK		1

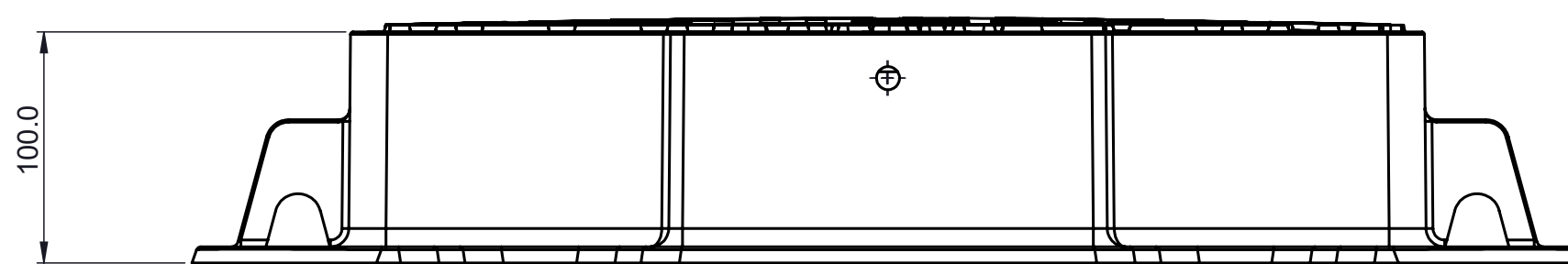
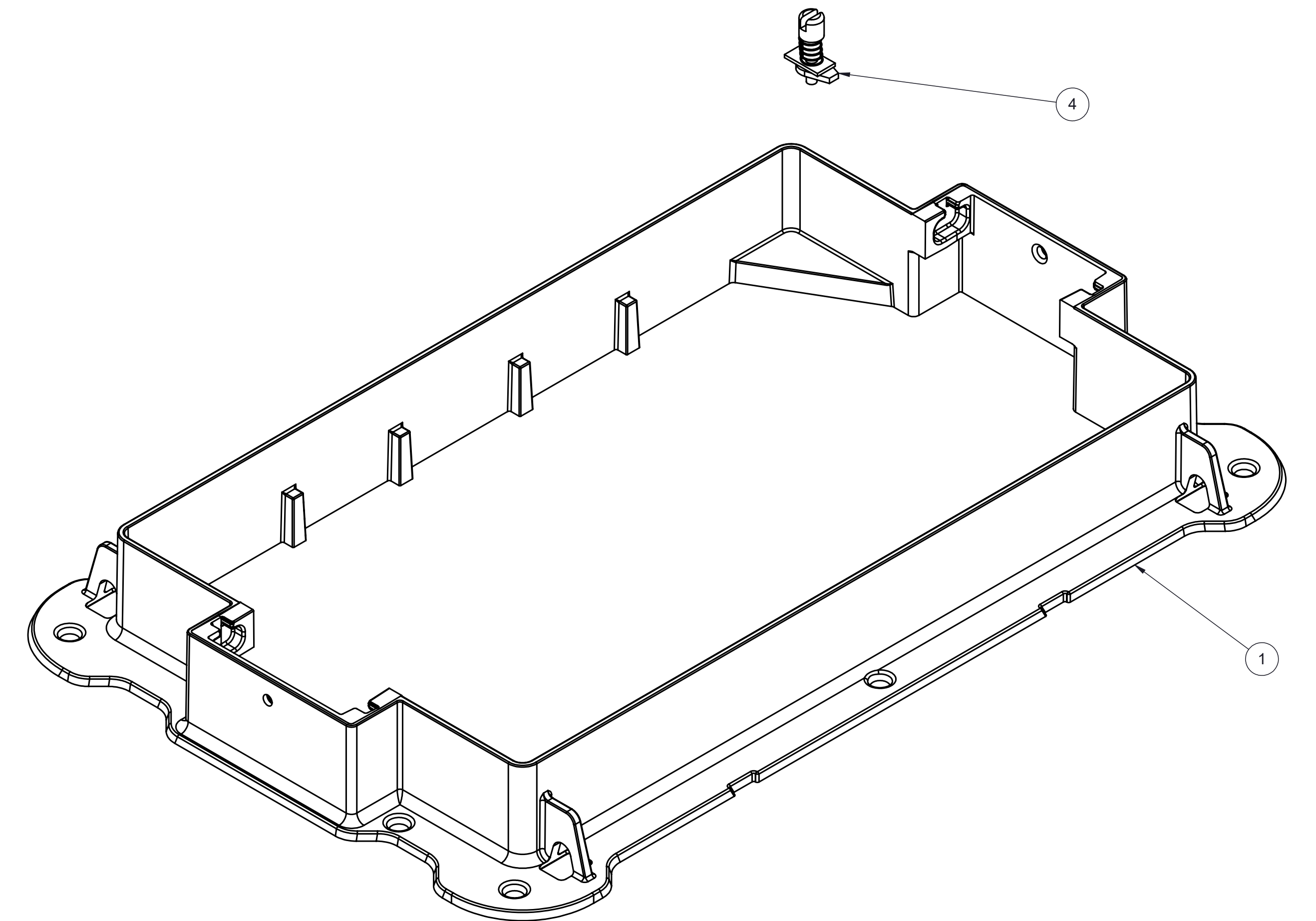
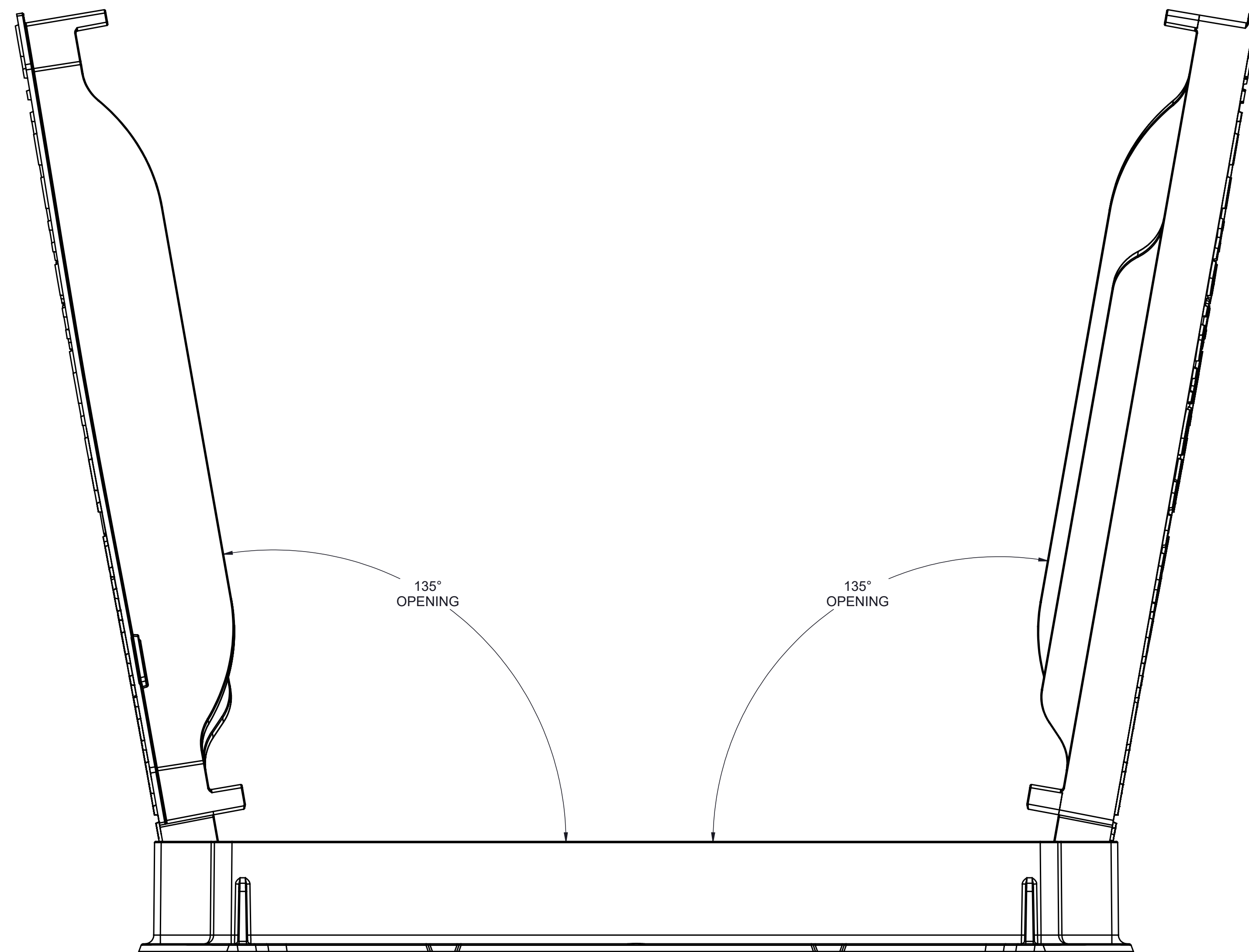
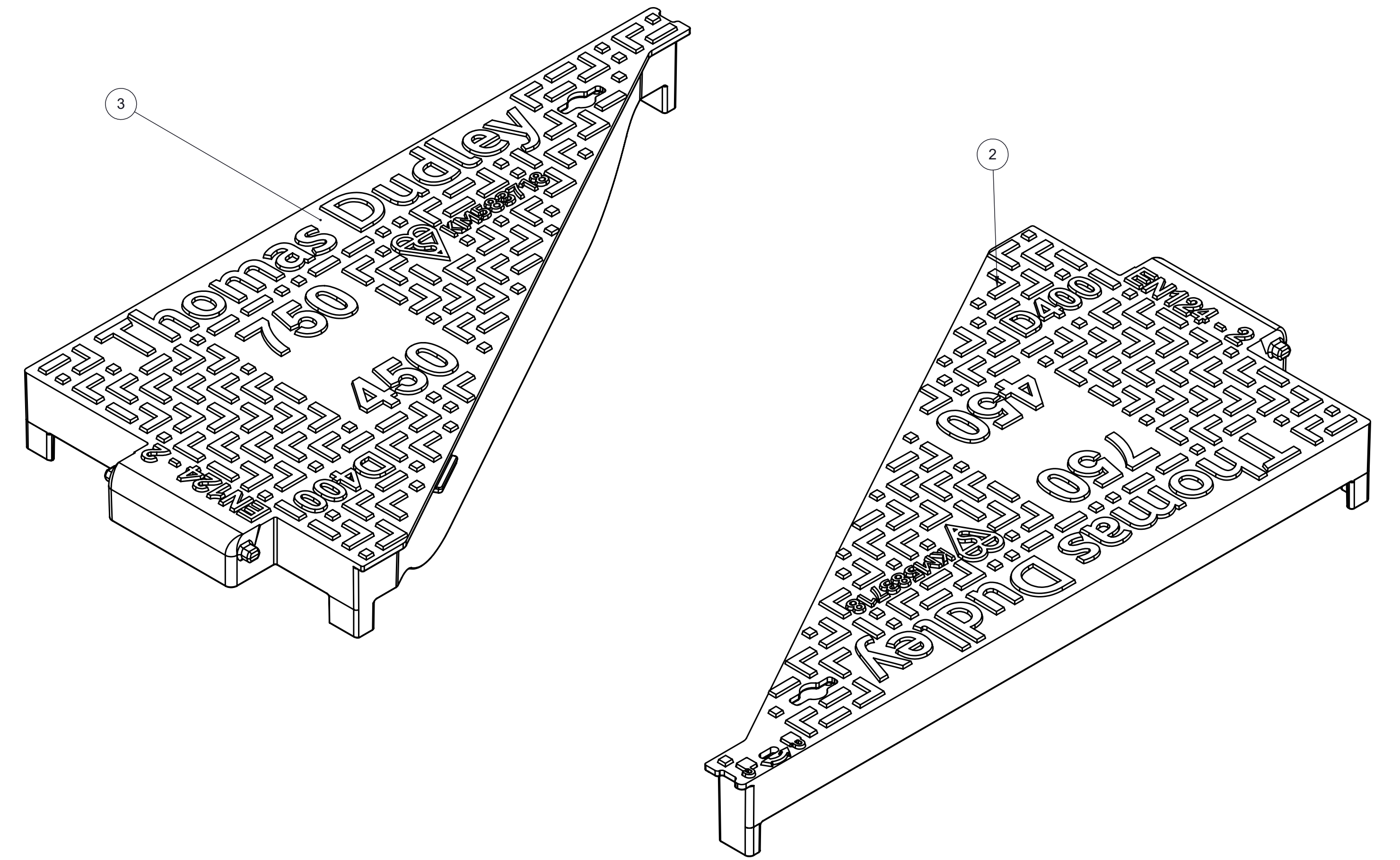
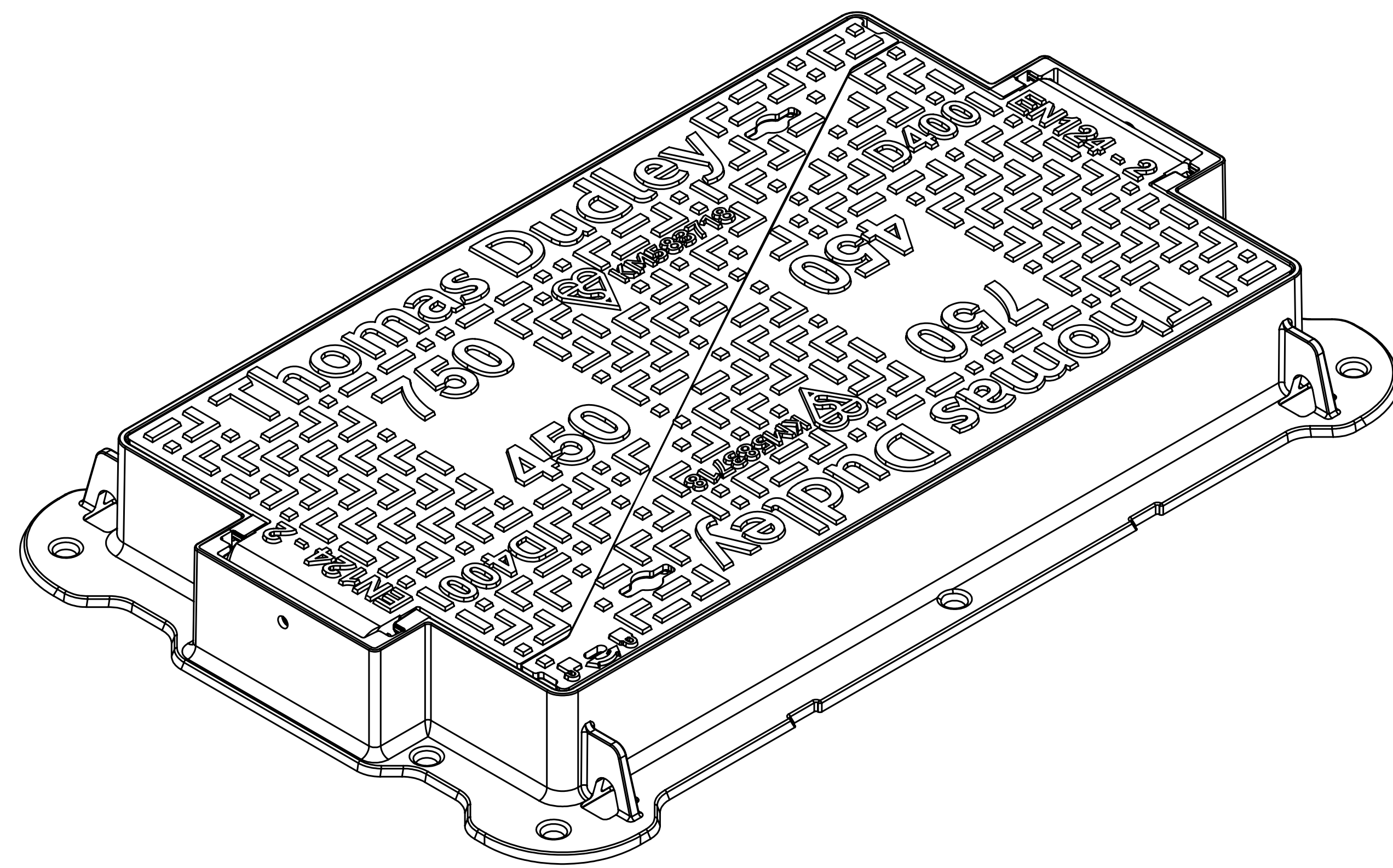
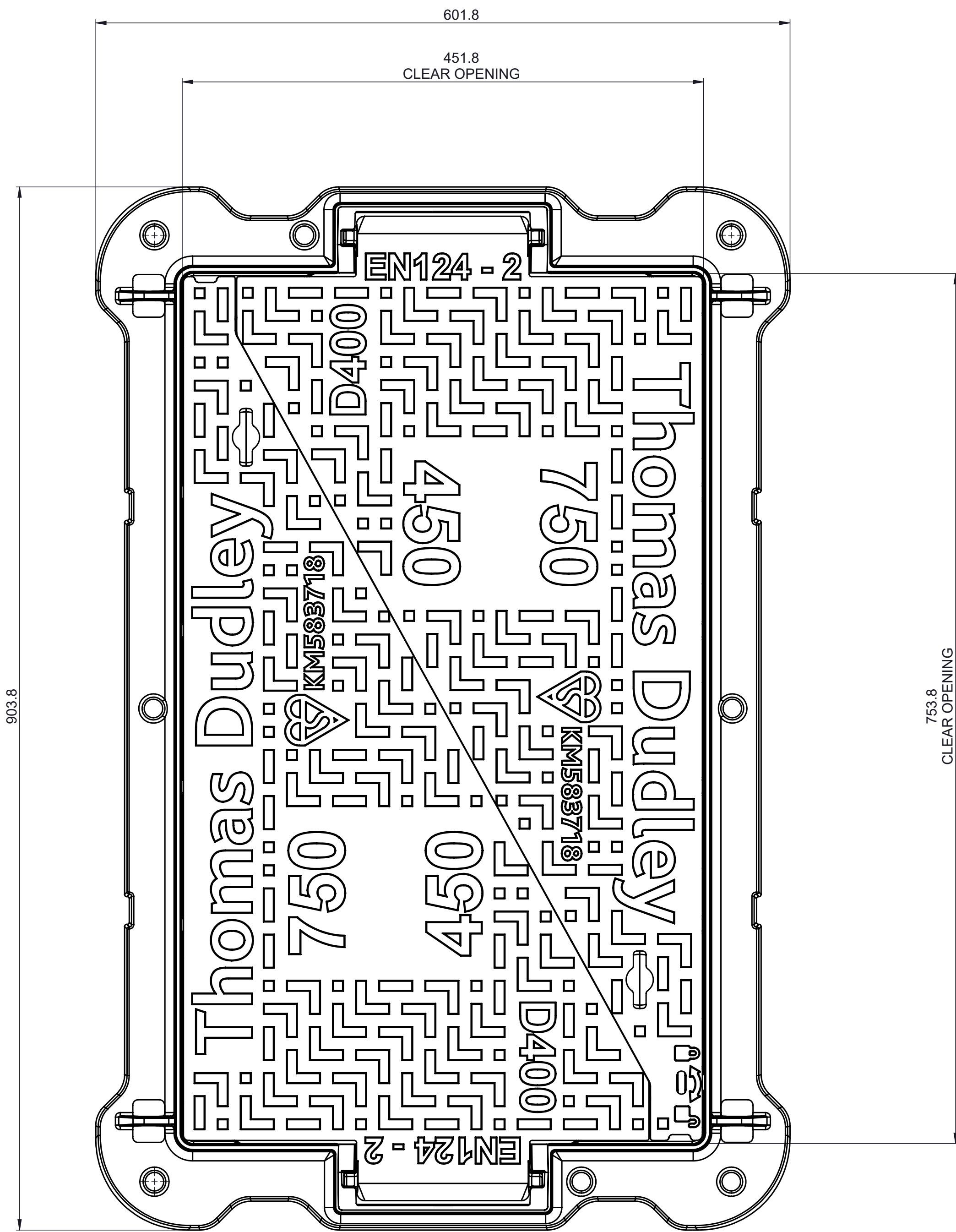

- GENERAL NOTES:
1. DEPTH OF INSERTION 80MM
 2. SOLID FLANGES
 3. HINGED AS STANDARD

PART No.	REFER TO COMPONENT	REFER TO COMPONENT
	MATERIAL	APPLIED FINISH & COLOUR

CC MC FIRST ISSUE 9603021 1
 MOD CHK MODIFICATION DATE ISS
Thomas Dudley Ltd.
 P.O. Box 28, Birmingham New Road
 Dudley, West Midlands, DY1 4SN
 Telephone: 0121 530 7600
 www.thomasdudley.co.uk

This document and any design incorporated in it is the property of Thomas Dudley Ltd. It is strictly confidential and must be used only for the purpose for which it is supplied and expressly authorized. Reproduction, manufacture or communication to third parties, in whole or part without prior written authorization is strictly prohibited and is an infringement of Thomas Dudley Ltd's copyright and design right. Other intellectual property rights may also subsist in any part of this document or design or invention incorporated within them. Please contact Thomas Dudley Ltd for further information.

LINEAR TOLERANCE: ISO 8015:2007 TO CT-9 UNLESS SPECIFIED ON DRAWING
 DIMENSIONS IN mm
 DO NOT SCALE

DRAWN	CHECKED	SHEET
C CORBETT	M CRAMPHORN	1 of 1
DATE: 06/03/2023	DATE: 06/03/2023	SCALE: 1:3

PROJECT: UTILITY CASTINGS
 DESCRIPTION: 750 x 450 x 100 D400 Lift Out Hinge 2 part double hinge

DRG No.	ISSUE
14635	1