

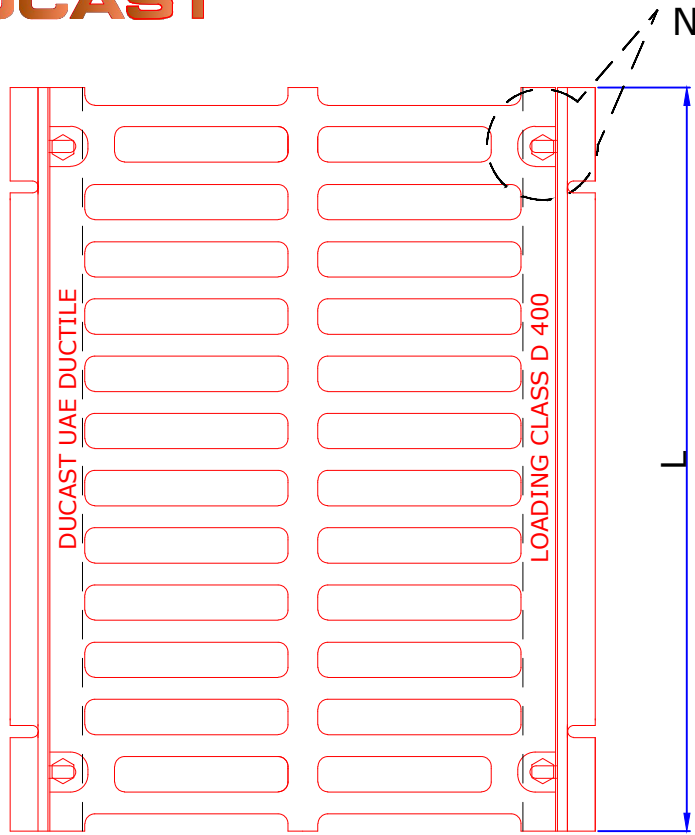

DUCAST

DUBAI. UAE.
 info@ducast.com
 www.ducast.com



PLAN

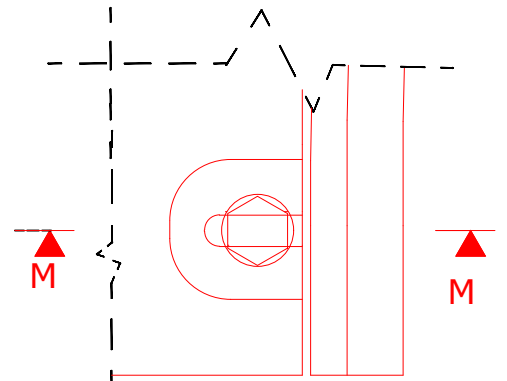

DETAIL N

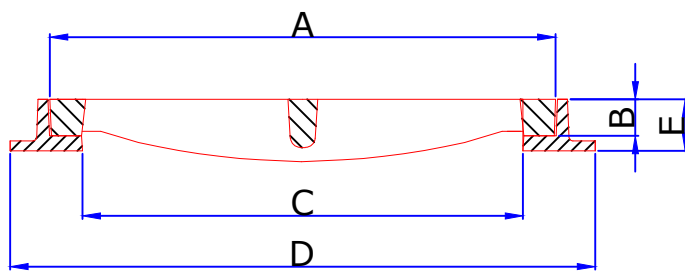

SECTIONAL VIEW

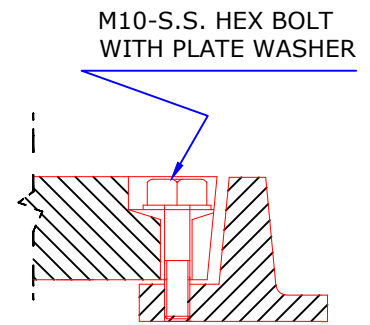

M10-S.S. HEX BOLT WITH PLATE WASHER

DRG. NO.	OVER ALL WIDTH OF GRATING A (mm)	GRATING THICKNESS B (mm)	CLEAR OPENING C (mm)	GRATING LENGTH L (mm)	OVER ALL WIDTH FRAME D (mm)	FRAME DEPTH E (mm)	LOADING (kN)
CH-9	500	35	450	750	600	50	400

DATE : 11-06-18	DESCRIPTION : 450MM CLEAR OPENING ,750mm LENGTH DUCTILE IRON LOADING CLASS D 400 CHANNEL GRATING WITH ANGLE BARS	REV : 01
DRAWN BY : GK		SCALE : NTS
CHECKED BY: RK		ALL DIMENSIONS ARE IN MM
APP.BY: AB		